

OLD STYLE
Manufactured until April 2019



4515 East 139th Street
 Grandview, MO 64030
 (800) 362-9055
 Fax (800) 362-1463
 www.PRIER.com

C-734/754 Heavy Commercial Mixing Hydrant

Application



- Commercial/Industrial
- Freezeless
- Hot & Cold Mixing
- ASSE/IAPMO Listed



PRIER C-734 Heavy Commercial Hot & Cold Mixing Hydrant provides a year round source of tempered water to areas of structures that are subject to freezing temperatures. The hydrant valve is connected to the supply piping in the heated portion of the structure, eliminating the possibility of freezing. The Hydrant is available with a self-draining vacuum breaker and backflow check valve (PRIER Model C-754) to protect against any cross contamination possibilities. Common applications include garbage can wash stations at restaurants and service station bay washers.

A removable operating key is provided to prevent unauthorized usage of the hydrant. No special installation tools are required.

Features

- Heavy pattern standard hydrant for use with or without polished brass or nickel bronze box
- Natural brass finish
- Heavy duty brass piping, stronger than ordinary copper tubing, with threaded and sealed joints
- Simple, solderless design for years of reliable operation
- Solid non-ferrous operating rod for long wear life
- Vacuum breaker and backflow preventor approved under ASSE 1011 and CSA B64.2
- Design enables stable and easy clamping to inner wall, providing secure hold on non-brick surfaces

Ordering

Wall Hydrant Only **C-734N10**

Hose Thread Outlet
 3- 3/4" Garden Hose
 5- Self-Draining
 Vacuum Breaker

Inlet
 N- 1" MPT x 3/4" FPT

- Length**
- 04- 4" Insertion
 - 06- 6" Insertion
 - 08- 8" Insertion
 - 10- 10" Insertion
 - 12- 12" Insertion
 - 14- 14" Insertion
 - 16- 16" Insertion
 - 18- 18" Insertion
 - 20- 20" Insertion
 - 22- 22" Insertion
 - 24- 24" Insertion
 - XX- Special Size



Optional Hydrant Box **C-734BX1**

Box Finish
 3- Standard Depth
 5- Deep Box
 for C-754

Box Finish
 1- Satin Nickel Plated
 2- Rough Brass





4515 East 139th Street
 Grandview, MO 64030
 (800) 362-9055
 Fax (800) 362-1463
 www.PRIER.com

Replacement Parts & Stems

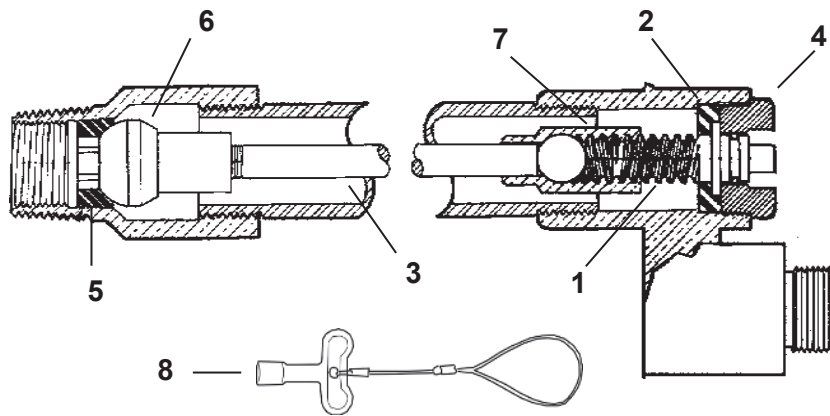

ID	Part No.	Description
1	392-4005	Drive Screw Assembly (Brass)
2	391-4008	Retainer Seal (Nylon)
3	Call PRIER	Operating Rod (Brass)
4	310-4009	Face Nut (Brass)
5	391-2018	Seat (Nylon)
6	392-2020	Plunger (Butyl with Brass Insert)
7	310-4003	Worm Sleeve (Brass)
8	C-108KT-808	Loose Key on Lanyard (Die Cast Aluminum)

Rough-In Dimensions

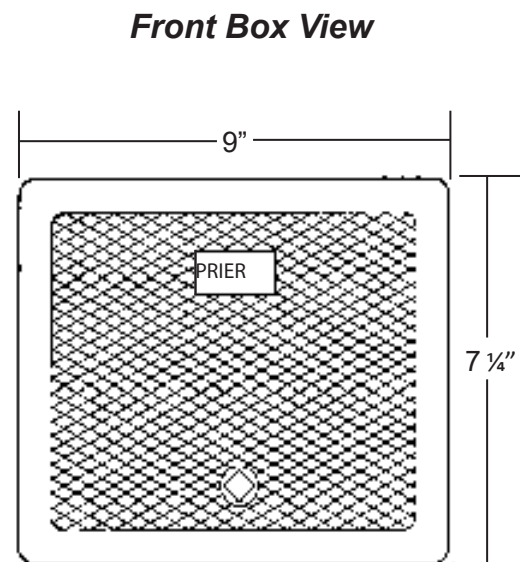
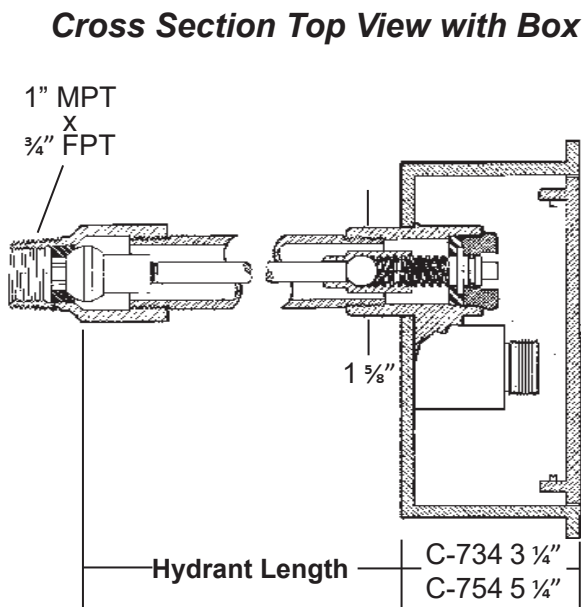

Specs

Furnish and install Freezeless Model C-734 (or C-754 with Anti-Siphon Vacuum Breaker and Backflow Check Valve) Commercial Hot & Cold Mixing Hydrant by PRIER. Hydrant shaft shall be brass with threaded and sealed connections. Hydrant shall have 3/4" hose connection with freezeless water flow and self-draining functions with brass operating rod. Hydrant shall be approved under ASSE standards. Two operating keys to be furnished with each hydrant. Hydrant insertion length to be * inches.

Optional: Furnish and install water box for each hydrant. Hydrant box shall be manufactured of solid cast brass with a polished brass or polished nickel bronze finish. Access to the water box shall be provided by the same operating key as the freezeless hydrant. *4" to 24" in 2" increments.