

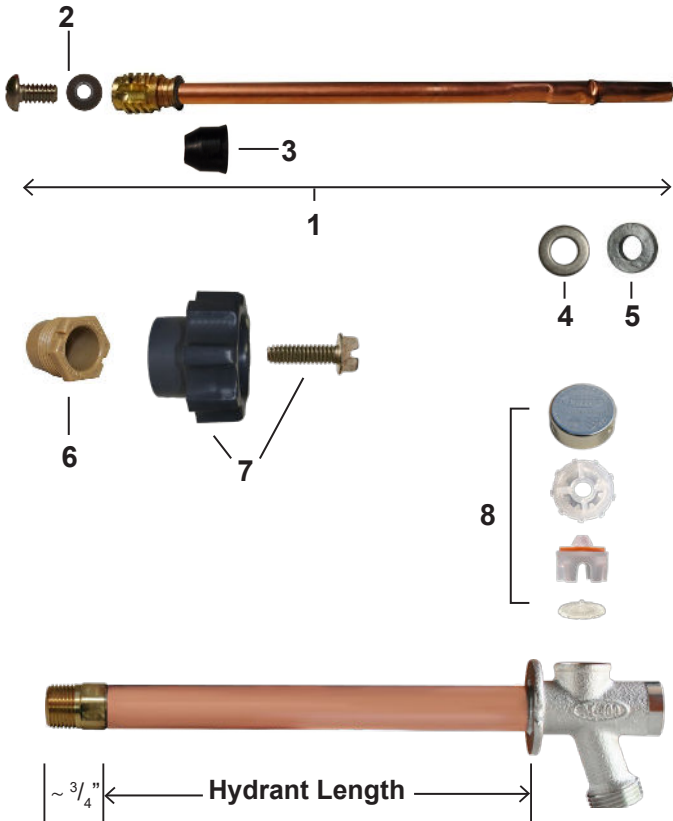

400 SERIES REPLACEMENT PARTS



ID	Part No.	Description
1	See Replacement Stems Section	Stem Assembly, Contains: 1, 4, 5
2	C-134KT-802	Seat Washer Replacement Kit (00 Beveled)
3	336-0002	Backflow Check Valve for 400 Series
4	324-1006	Washer (Stainless Steel)
5	336-0044	Packing for Left Hand Packing Nut
6	337-3001	Left Hand Thread Packing Nut (Plastic)
7	630-7965	Handle & Screw Kit (Grey Plastic Handle & Stainless Steel Screw)
	630-7975	Handle & Screw Kit (Beige Plastic Handle & Stainless Steel Screw)
8	630-7500	Vacuum Breaker Replacement Kit (Plastic Parts with Rubber Washer)
	630-7755	Service Kit for 300/400/500 Series Contains: 2, 3, 4, 5, 6
	630-8500	Complete Service, Handle & Vacuum Breaker Kit

*The 630-7755 Wall Hydrant Repair Kit includes parts for the 300, 400 and 500 Series hydrants, some of which are not pictured here. When repairing a hydrant you will have parts left over.

REPLACEMENT STEMS



H Style Manufactured April 2013 - Present

Part No.	Style	Stem Length	Description
M-231-32CC	H	4" OAL	Close Coupled Stem for 400 Series Hydrant
M-231-3204	H	6 ⁹ / ₁₆ " OAL	Stem for 400 Series 4" Hydrant
M-231-3206	H	8 ⁹ / ₁₆ " OAL	Stem for 400 Series 6" Hydrant
M-231-3208	H	10 ⁹ / ₁₆ " OAL	Stem for 400 Series 8" Hydrant
M-231-3210	H	12 ⁹ / ₁₆ " OAL	Stem for 400 Series 10" Hydrant
M-231-3212	H	14 ⁹ / ₁₆ " OAL	Stem for 400 Series 12" Hydrant
M-231-3214	H	16 ⁹ / ₁₆ " OAL	Stem for 400 Series 14" Hydrant

**For stems manufactured before 2013, see 400 Series retired style spec sheet at PRIER.com. For older styles made prior to 2007, see the retired 500 Series spec sheet.

4515 E. 139th Street Grandview, MO 64030 | (800) 362-9055 | PRIER.com

*Per ASSE 1019 Code, do not leave on for more than 12 continuous hours.

478-Z

ORIGINAL STYLE
Manufactured 2006-April 2013



4515 East 139th Street
 Grandview, MO 64030
 (800) 362-9055
 Fax (800) 362-1463
 www.PRIER.com

400 Series Freezeless Wall Hydrant



- Freezeless
- Anti-Siphon
- Solid Brass Body



Replacement Parts and Stems

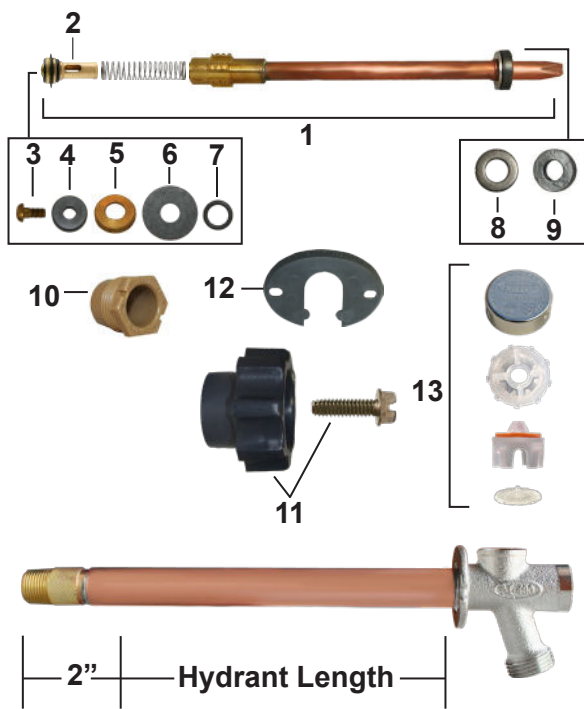

ID	Part No.	Description
1	See Below	Stem Assembly, Contains: 1-9
2	231-3201	BFP Sub Assembly
3	910-3008	Bibb Screw (Brass)
4	936-3012	Bibb Washer (Rubber)
5	310-3016	Cage Washer (Brass)
6	936-3011	BFP Washer (Rubber)
7	936-3002	Stem End O-Ring (Rubber)
8	324-1006	Washer (Stainless Steel)
9	339-3002	Packing for Left Hand Packing Nut (Graphite)
10	337-3001	Left Hand Thread Packing Nut (Plastic)
11	630-7965	Handle & Screw Kit (Grey Plastic Handle & Stainless Steel Screw)
	630-7975	Handle & Screw Kit (Beige Plastic Handle & Stainless Steel Screw)
12	337-3012	Space Wedge (Grey, Plastic)
	337-3013	Space Wedge (Beige, Plastic)
13	630-7500	Vacuum Breaker Replacement Kit (Plastic Parts with Rubber Washer)
	630-7755	Service Kit for 300/400/500 Series Contains: 3-10
	630-8500	Complete Service, Handle & Vacuum Breaker Kit

2" Hydrant Length

*The 630-7755 Wall Hydrant Repair Kit includes parts for the 300, 400 and 500 Series hydrants, some of which are not pictured here. When repairing a hydrant you will have parts left over.

*The 630-7500 Universal Vacuum Breaker Kit is manufactured to fit this model, along with all current and past PRIER and Mansfield style residential hydrants. Please note this cap is now aluminum.



Stem Overall Length (OAL)
 Old Style Manufactured 2006 - April 2013

Part No.	Stem Length	Description
M-123-4090	8" OAL	Stem for 400 Series 4" Hydrant
M-123-4092	10" OAL	Stem for 400 Series 6" Hydrant
M-123-4093	12" OAL	Stem for 400 Series 8" Hydrant
M-123-4094	14" OAL	Stem for 400 Series 10" Hydrant
M-123-4095	16" OAL	Stem for 400 Series 12" Hydrant
M-123-4096	18" OAL	Stem for 400 Series 14" Hydrant

400 Series Stems are made to fit the 400 Series Wall Hydrants only. They are not interchangeable with any other models. **For the **old style 500 Series** wall hydrant stems, see 500 Series retired style spec sheet at www.PRIER.com.