



Build With Purpose

# P-RH1 Flush Mount Roof Hydrant

Find us in

**MasterSpec**

a product of The American Institute of Architects

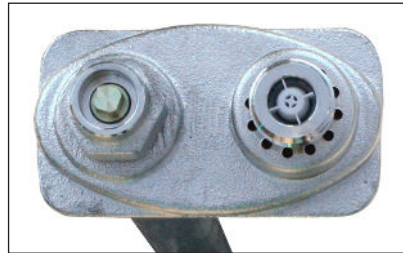

top view

## With Integral P-004 Vacuum Breaker and Dual Backflow Preventer

PRIER's P-RH1 Flush Mount Roof Hydrant provides a year round source of water to roof surfaces in areas with freezing temperatures. The C-650 hydrant is combined with galvanized pipe and a mounting bracket. The hydrant is installed flush to the roof, allowing the hose to run 360°. The hydrant valve is connected to the supply piping in the heated portion of the structure, and is self-draining, eliminating the possibility of freezing. A removable operating key is provided for operation.

The PRIER Roof Mounting Bracket enables the hydrant to be mounted to any structural member with rigid support, instead of to the skin of the roof like competitive products.

This hydrant requires only a single penetration point of 1 3/4", and can be mounted to concrete, wood, steel, I-beams, trusses, perlin or other structural members with standard construction materials (Unistrut, all-thread, or other).

- **Anti-Siphon**
- **Freezeless**
- **Self-Draining**
- **Commercial / Industrial**

## FEATURES

- Patented PRIER "triple seal" positive shutoff system offers triple redundancy to assure shutoff
- High flow rate, 15 gallons per minute at 25 PSI differential
- Mounts to any roof structural member (truss, I-beam, concrete roof, or other)
- Single hole penetration of 1 3/4"
- Single person installation with standard tools
- ASSE 1052 approved vacuum breaker
- Freezeless anti-siphon hydrant is flush to the roof allowing hose to run 360°
- Per ASSE 1052, pressure rated to 125 PSI, temperature to 140° F
- Heavy duty construction
- Self draining with 1/8" NPT drainage port
- Repair can be easily accomplished at roof level
- Designed to be installed with standard construction materials (Unistrut, threaded rod, or other)
- 3/4" garden hose threads standard; 1" threads optional
- 3/4" female NPT inlet connection
- Includes operating key
- Adjustable bracket to accommodate roof angles up to 2/12 pitch

## ORDERING

# P-RH1



# P-RH1 REPLACEMENT PARTS AND STEMS

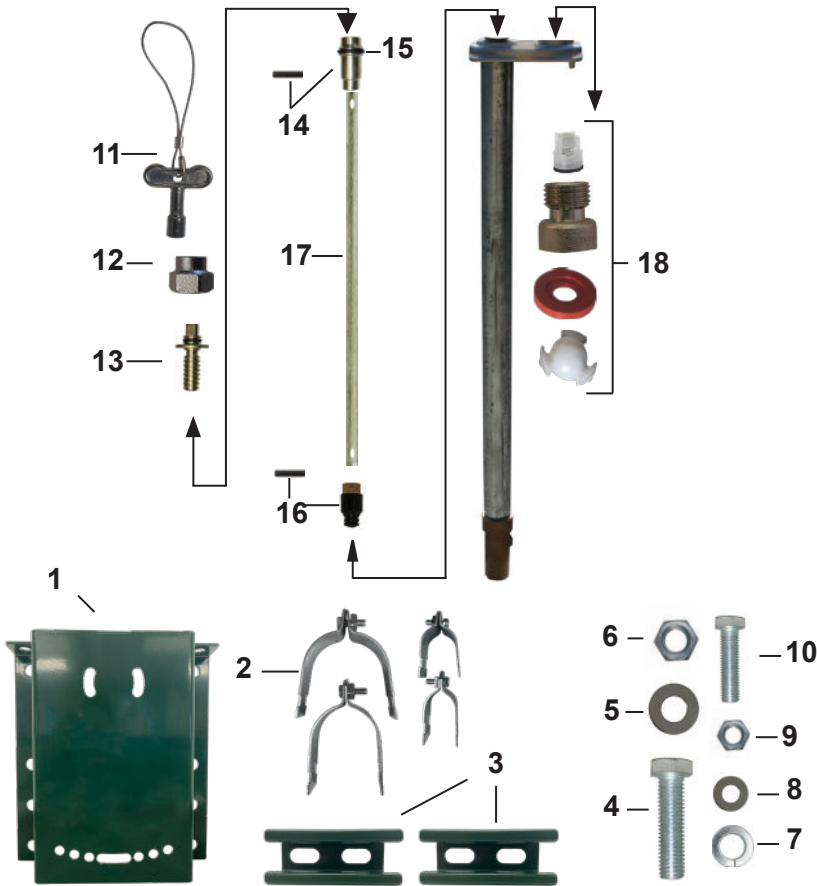

ID	Part No.	Description
1	314-0021	Mounting Bracket
2	399-7002	1" Pipe Clamp Assembly for P-RH1, P-RH2, P-RH3
2	399-7003	2 1/2" Pipe Clamp Assembly for P-RH4
3	314-7012	Unistrut Steel Struts
4	314-0028	1/2" Mounting Bolt
5	314-0029	1/2" Flat Washer
6	314-0030	1/2" Mounting Nut
7	314-0025	3/8" Lock Washer
8	324-1003	3/8" Flat Washer
9	314-0027	3/8" Hex Nut
10	314-0035	3/8" Bolt
11	C-108KT-808	Loose Key on Lanyard
12	300-6003	Valve Stem Cap
13	C-634KT-809	Worm Drive Assembly
14	C-634KT-808	Worm Sleeve Assembly
15	336-0001	O-Ring for Worm Sleeve
	P-260KT-802	Stopper Assembly, Contains: 15, 16
16	399-7001	Stopper (EPDM over Brass)
17	Call PRIER	Stem Shaft
18	C-634KT-806	Vacuum Breaker Assembly
	P-231-0803	3' Stem Assembly, 37 1/8" OAL Contains: 14, 15, 16, 17

## ROUGH-IN DIMENSIONS

**Side Hydrant View**

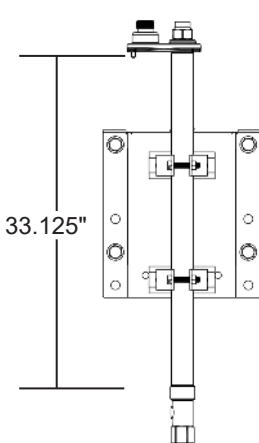

**Bottom Bracket View**

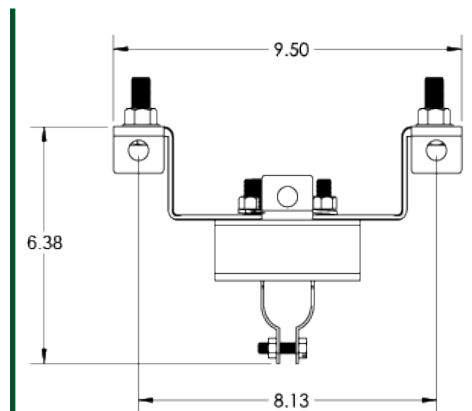

**Front Bracket View**

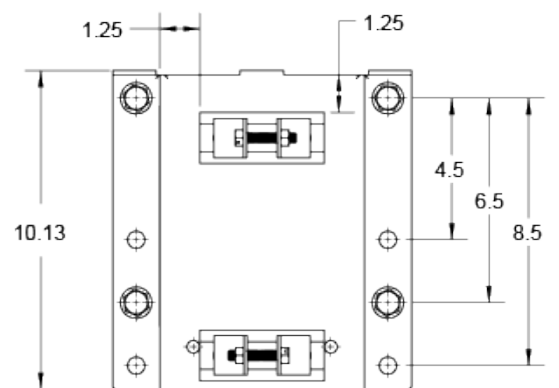

## SPECS

Furnish and install Model P-RH1 Commercial Flush Mount Roof Hydrant manufactured by PRIER Products, Inc. Hydrant shall be installed through a 1 3/4" single penetration in the roof and mounted to the interior structure with the Universal Roof Hydrant Mounting Bracket (P-RMB) provided. This bracket must be manufactured of heavy gauge powder coated steel and must allow for adjustment to meet roof angles up to 2/12 pitch. The mounting bracket shall be mounted to concrete, a roofing truss, steel I-beam or interior wall with standard construction materials (all-thread, Unistrut or other). The hydrant shall be flush mounted and have automatic draining capabilities with integral vacuum breaker/backflow preventer. Hydrant head and inlet shall be brass with freezeless water flow and self draining functions, one piece valve plunger, satin nickel finish and a triple-seal shut off mechanism. Hydrant shall be capable of flowing a minimum of 15 gallons per minute at 25 PSI differential. The hydrant shall have a 3/4" inlet and a 1/8" NPT drainage port to be connected to the drain waste line inside the structure. Hydrant shall be approved under the ASSE 1052 standard. The roof penetration is to be sealed by the roofing contractor in accordance with the roofing codes and conditions in their municipality.