

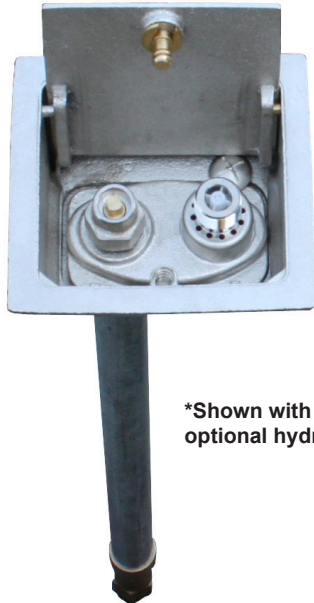

P-650 Heavy Commercial Ground Hydrant



*Shown with optional hydrant box

With Integral P-004 Vacuum Breaker and Dual Backflow Preventer

PRIER P-650 Heavy Commercial Ground Hydrant provides a year round source of water to areas subject to freezing temperatures. The hydrant is installed flush to surface, eliminating interference with machinery or pedestrian traffic.

The hydrant valve is connected to the supply piping below the freeze line, and is self draining, eliminating the possibility of freezing. An operating key is provided to prevent unauthorized usage of the hydrant.

- Commercial / Industrial
- Freezeless
- Anti-Siphon
- Double Backflow Check Valve
- Self-Draining

FEATURES

- Heavy pattern standard hydrant for use with or without brass or satin nickel box
- ASSE 1052 approved double backflow preventer and vacuum breaker
- Heavy duty galvanized piping, with options for all brass construction
- Simple, solder-less design with threaded and sealed joints for years of reliable operation
- Repair can be easily accomplished at ground level
- No special installation or service tools are required
- Includes operating key
- 5 full hose threads

ORDERING

Ground Hydrant Only

P-650N02

Hose Thread Outlet
0- 3/4" Garden Hose
1- 1" Hose

Inlet
N- 3/4" FPT

Length
1- 1' Bury Depth
2- 2' Bury Depth
3- 3' Bury Depth
4- 4' Bury Depth
5- 5' Bury Depth
6- 6' Bury Depth



Optional Hydrant Box

C-634BX1

Box Finish
BX1- Satin Nickel Plated
BX2- Rough Brass
BX3- Aluminum
RB1- Round Box (Satin Nickel Plated)

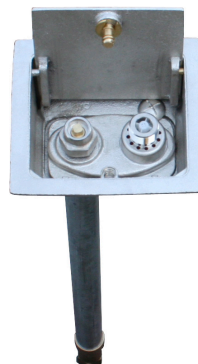

BX1



BX2



BX3



RB1

*Optional box is rated at light duty. For installations with hydrant box, both freezeless hydrant and box need to be ordered.

P-650 REPLACEMENT PARTS

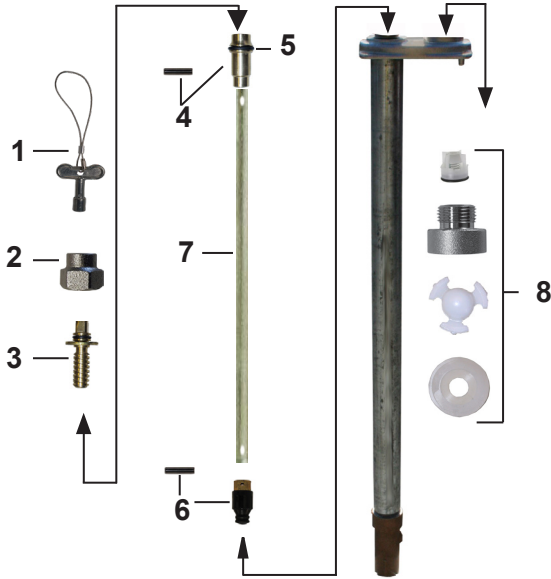

ID	Part No.	Description
1	C-108KT-808	Loose Key on Lanyard
2	300-6003	Valve Stem Cap
3	C-634KT-809	Worm Drive Assembly
4	C-634KT-808	Worm Sleeve Assembly
5	336-0001	O-Ring for Worm Sleeve
6	P-260KT-802	Stopper Assembly
7	Call PRIER	Stem Shaft
8	C-634KT-806	Vacuum Breaker Assembly
4-7	231-0801	Stem Assembly for 1' P-650, 13 1/4" OAL
4-7	231-0802	Stem Assembly for 2' P-650, 25 1/4" OAL
4-7	231-0803	Stem Assembly for 3' P-650, 37 1/4" OAL
4-7	231-0804	Stem Assembly for 4' P-650, 49 1/4" OAL
4-7	231-0805	Stem Assembly for 5' P-650, 61 1/4" OAL
4-7	231-0806	Stem Assembly for 6' P-650, 73 1/4" OAL
4-7	231-0807	Stem Assembly for 7' P-650, 85 1/4" OAL

ROUGH-IN DIMENSIONS

Side Hydrant View with Box

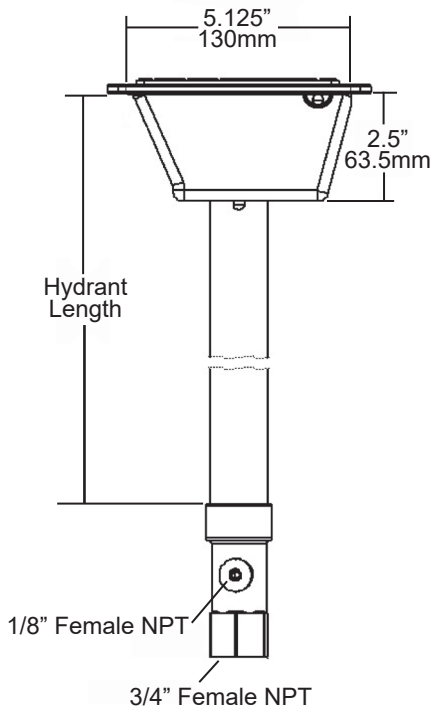

Top Box View

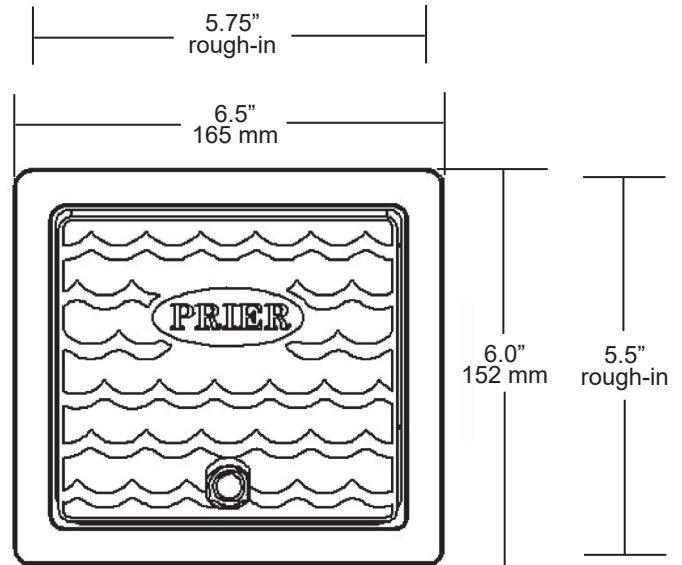

SPECS

Furnish and install PRIER's P-650 Heavy Commercial key-operated ground hydrant manufactured by PRIER Products, Inc. Hydrant shall be approved to ASSE 1052 and UPC standards and shall be installed with a water box. Hydrant box shall be manufactured of solid cast brass with a rough brass or satin nickel (choose one) finish. Access to the water box shall be provided by the same operating key as the hydrant. The hydrant must be installed flush to surface to allow machinery and pedestrian traffic without damage to hydrant. Hydrant shaft shall be heavy duty piping with threaded and sealed connections. Hydrant shall have 3/4" or 1" (choose one) hose connection with freezeseless water flow and self-draining functions with solid operating rod. Hydrant insertion depth to be * feet. *1' to 7' in 1' increments. Hydrant box is optional.